

System No. W-L-5300

October 23, 2014

F Rating — 2 Hr

T Rating — 1 Hr

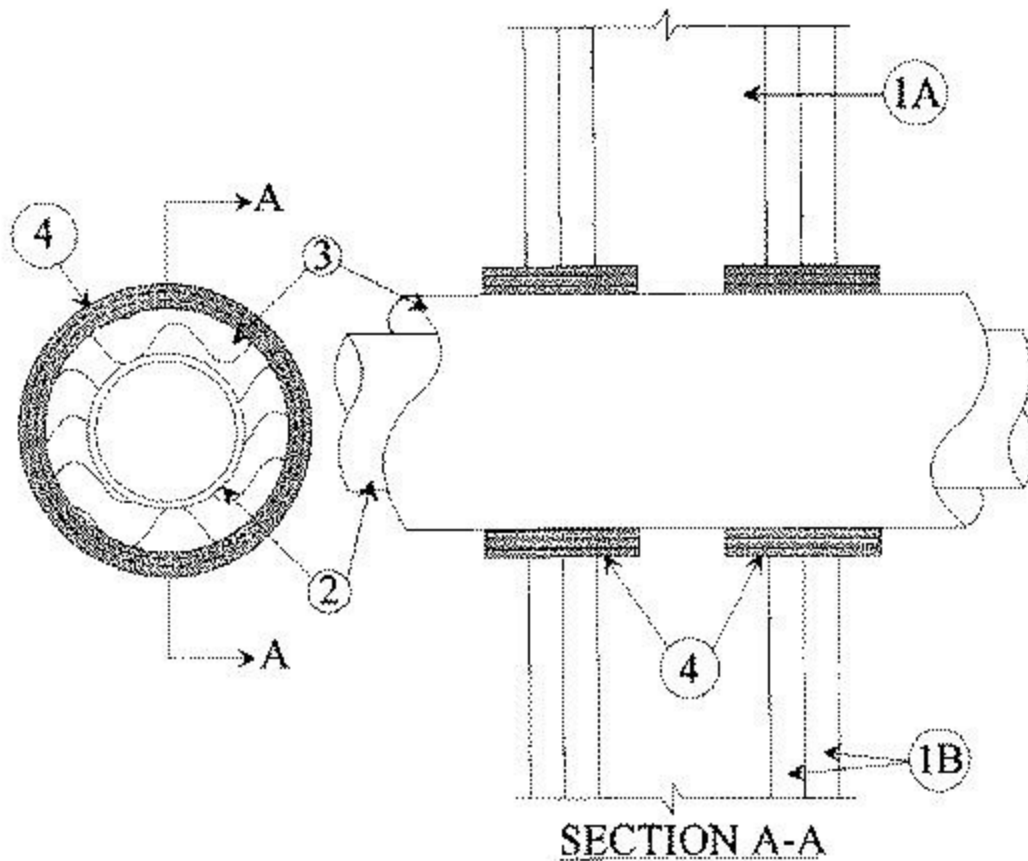

1. **Wall Assembly** — The fire-rated gypsum wallboard/stud wall assembly shall be constructed of the materials and in the manner specified in the individual U300 or U400 Series Wall and Partition Designs in the UL Fire Resistance Directory and shall include the following construction features:

A. **Studs** — Wall framing may consist of either wood studs or steel channel studs. Wood studs to consist of nom 2 by 4 in. lumber spaced 16 in. OC. Steel studs to be min 2-1/2 in. wide and spaced max 24 in. OC.

B. **Gypsum Board*** — Two layers of nom 5/8 in. thick gypsum wallboard, as specified in the individual Wall and Partition Design. Max diam of opening is 18 in.

2. **Steel Pipe** — Nom 10 in. diam (or smaller) Schedule 10 (or heavier) steel pipe. One pipe to be installed either concentrically or eccentrically within the firestop system. Pipe to be rigidly supported on both sides of floor or wall assembly.

3. **Pipe Covering*** — Nom 3 in. thick hollow cylindrical heavy density (min 3.5 pcf) glass fiber units jacketed on the outside with an all service jacket. Longitudinal joints sealed with metal fasteners or factory-applied self-sealing lap tape. Transverse joints secured with metal fasteners or with butt tape supplied with the product. The annular space shall be min 1/2 in. to max 3/4 in.

See **Pipe and Equipment Covering — Materials** (BRGU) category in the Building Materials Directory for names of manufacturers. Any pipe covering material meeting the above specifications and bearing the UL Classification Marking with a Flame Spread Index of 25 or less and a Smoke Developed Index of 50 or less may be used.

4. **Fill, Void or Cavity Material* — Wrap Strip** — Nom 1/4 in. thick by 2 in. wide intumescent wrap strip. The wrap strip is continuously wrapped around the outer circumference of the pipe covering three times and slid into annular space approx 1-5/8 in. such that approx 3/8 in. of the wrap strip protrudes from the wall surface. When multiple wrap strips are used to achieve the required total length, the ends are to be butted end-to-end and held in place with aluminum tape. Wrap strips are installed on each side of wall.

EVERKEM DIVERSIFIED PRODUCTS INC — Flame Tech Wrap Strip

*Bearing the UL Classification Mark

* **Indicates such products shall bear the UL or cUL Certification Mark for jurisdictions employing the UL or cUL Certification (such as Canada), respectively.**