

## System No. W-L-2601

October 23, 2014

**F Ratings — 1 and 2 Hr (See Item 1)**

**T Ratings — 0 and 2 Hr (See Item 1)**

**L Rating at Ambient — Less than 1 CFM/ft<sup>3</sup>**

**L Rating at 400° F — Less than 1 CFM/ft<sup>3</sup>**

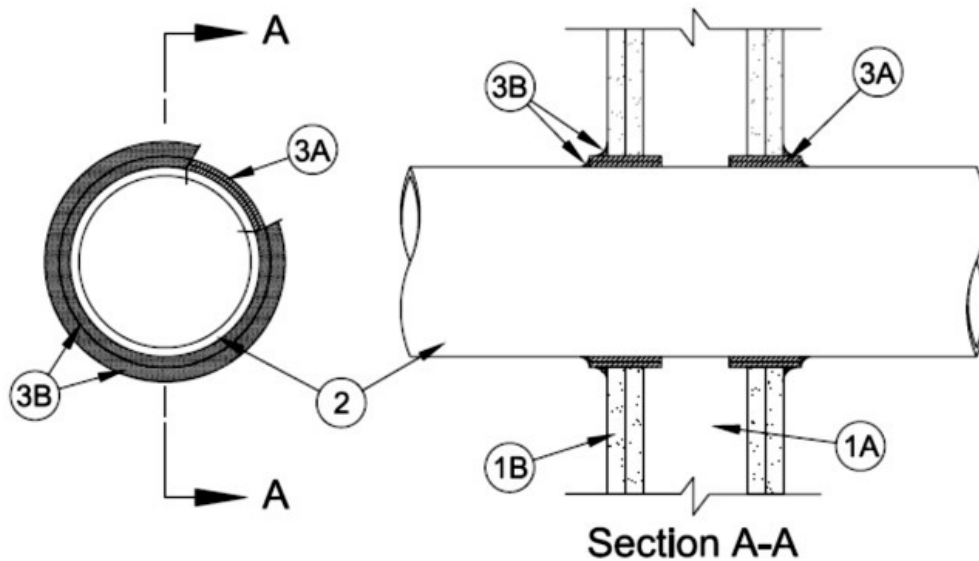

1. **Wall Assembly** — The 1 or 2 h fire rated gypsum board/stud wall assembly shall be constructed of the materials and in the manner specified in the individual U300, U400 or V400 Series Wall and Partition Designs in the UL Fire Resistance Directory and shall include the following construction features:

A. **Gypsum Board** — Min 5/8 in. (16 mm) thick. The gypsum board type, thickness, number of layers and orientation shall be as specified in the individual U300, U400 or V400 Wall and Partition Design. Max diam of opening is 5 in. (127 mm).

B. **Studs** — Wall framing shall consist of either wood or steel channel studs. Wood studs to consist of nom 2 by 4 in. (51 by 102 mm) lumber spaced 16 in. (406 mm) OC. Steel studs to be min 3-1/2 in. (89 mm) wide and spaced max 24 in. (610 mm) OC.

**The hourly F Rating of the firestop system is equal to the hourly fire rating of the wall assembly in which it is installed. The hourly T Rating is 0 hr or 2 hr for 1 or 2 hr fire rated constructions, respectively.**

2. **Through Penetrant** — One nonmetallic pipe or tube to be installed eccentrically or concentrically within the firestop system. Annular space to be min 1/4 in. (6 mm) to max 1-1/4

in. (32 mm). Pipe or tube to be rigidly supported on both sides of the wall assembly. The following types and sizes of nonmetallic pipes and tubes may be used:

A. **Polyvinyl Chloride (PVC) Pipe** — Nom 3 in. (76 mm) diam (or smaller) Schedule 40 (or heavier) solid core or cellular core PVC pipe for use in closed (process or supply) or vented (drain, waste or vent) piping systems.

3. **Firestop System** — The firestop system shall consist of the following:

A. **Fill, Void or Cavity Material\* - Wrap Strip** — One layer of nom 1/4 in. (6 mm) thick by 2 in. (51 mm) wide intumescent wrap strip wrapped around the outer circumference of the pipe and slid into the annular space such that wrap strip protrudes 1/4 in. (6 mm) from both surfaces of wall. Wrap strip secured with tape or tie wire.

**EVERKEM DIVERSIFIED PRODUCTS INC** — Flame Tech Wrap Strip

B. **Fill, Void or Cavity Material\* - Sealant** — Min 1/2 in. (13 mm) crown bead of fill material applied at the pipe/wrap strip interface. Min 1/2 in. (13 mm) depth of sealant to be placed within any annular spaces between the wrap strip and the periphery of opening.

**EVERKEM DIVERSIFIED PRODUCTS INC** — Firestop 814+

\*Bearing the UL Classification Mark

\* **Indicates such products shall bear the UL or cUL Certification Mark for jurisdictions employing the UL or cUL Certification (such as Canada), respectively.**