

System No. W-L-2599

October 23, 2014

F Rating — 4 Hr

T Ratings— 2-3/4 and 4 Hr (See Items 3 and 3A)

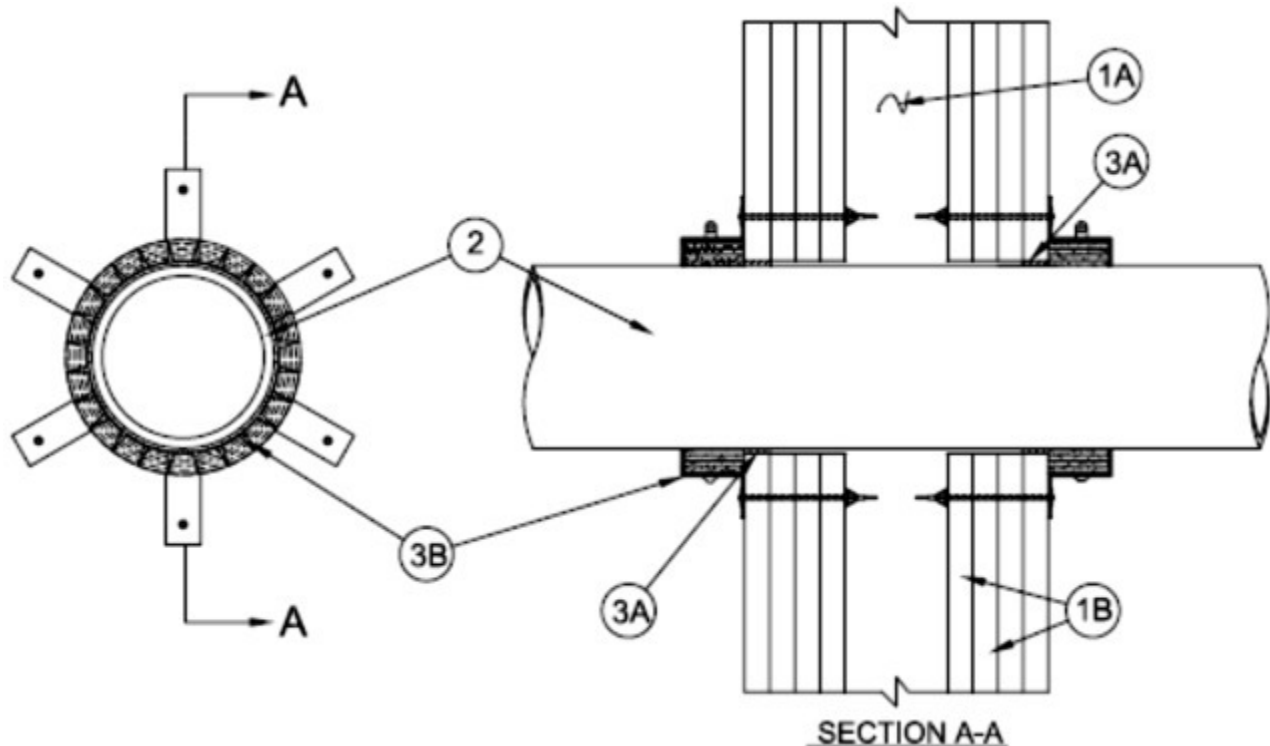

1. **Wall Assembly** — The 4 hr fire rated gypsum board/stud wall assembly shall be constructed of the materials and in the manner specified in the individual U400 or V400 Series Wall and Partition Designs in the UL Fire Resistance Directory and shall include the following construction features:
 - A. **Studs** — Wall framing shall consist of min 2-1/2 in. (64 mm) wide steel channel studs spaced max 24 in. (610 mm) OC.
 - B. **Gypsum Board*** — Thickness, type, number of layers and fasteners as required in the individual Wall and Partition Design. Max diam of opening is 5 in. (12 mm).
2. **Through Penetrants** — Nom 4in. (102 mm) diam (or smaller). Schedule 40 solid core PVC pipe for use in closed (process or supply) or vented (drain, waste or vent) piping systems. Pipe to be installed either concentrically or eccentrically within the firestop system. The annular space between the pipe and periphery of opening shall be min 0 in. (point contact) to max 1/2 in. (13 mm). Pipe to be rigidly supported on both sides of wall assembly.
3. **Firestop System** — The firestop system shall consist of the following:
 - A. **Fill, Void or Cavity Materials * - Caulk** — Min thickness of 5/8 in. (16 mm) of caulk applied within annulus, flush with both surfaces of wall assembly.

EVERKEM DIVERSIFIED PRODUCTS INC — Firestop 814+

B. Firestop Device* — Galv steel collar lined with an intumescent material sized to fit specific diam of the through penetrant. Device to be installed around through penetrant in accordance with accompanying installation instructions. Device incorporates anchor tabs for securement to both surfaces of the wall by means of 1/4 in. diam by 4 in. (6 by 102 mm) long steel hollow wall anchors.

EVERKEM DIVERSIFIED PRODUCTS INC — Flame Tech Firestop Collar

T Rating is 2-3/4 hours when Item 3 is used.

- 3A. Firestop System — (Alternate to Item 3)** — The firestop system shall consist of the following:
- A. Fill, Void or Cavity Materials* - Caulk** — (Optional) — Min thickness of 5/8 in. (16 mm) of caulk applied within annulus flush with both surfaces of wall assembly.

EVERKEM DIVERSIFIED PRODUCTS INC — Firestop-814+

B. Fill, Void or Cavity Material* - Wrap Strip — Two layers of nom 1/4 in. (6 mm) thick by 2 in. (1 mm) wide intumescent wrap strip individually wrapped around the outer circumference of the pipe such that wrap strip is flush with both surfaces of wall. Butted ends in successive layers shall be offset. Wrap strip secured with tape, wire or tie wire.

EVERKEM DIVERSIFIED PRODUCTS INC — Flame Tech Wrap Strip

C. Steel Collar — Collar fabricated from coils of precut min 0.016 in. thick (No. 28 gauge) galv steel available from fill material manufacturer. Collar shall be nom 2 in. (51 mm) deep with 1 in.(25 mm) wide by 1-1/2 in. (38 mm) long anchor tabs on 4 in. (102 mm) centers to secure to both surfaces of wall. In addition, collar contains retainer tabs, 1/2 in. (13 mm) wide by 3/4 in. (19 mm) long, located opposite the anchor tabs. Collar shall be wrapped over the wrap strip, overlapping min 1 in. The retainer tabs are folded 90 deg towards the pipe to maintain the annular space around the pipe and to retain the wrap strip. Collar secured to both surfaces of wall at each anchor tab by means of 1/4 in. diam by 4 in. (6 by 102 mm) long steel hollow wall anchors in conjunction with 1/4 in. by 5/8 in. (6 by 16 mm) diam washers.

T rating is 4 hr when Item 3A is used.

*Bearing the UL Classification Mark

++Bearing the UL Listing Mark

*** Indicates such products shall bear the UL or cUL Certification Mark for jurisdictions employing the UL or cUL Certification (such as Canada), respectively.**