

System No. W-J-2264

October 23, 2014

F Rating — 2 Hr

T Rating — 1/2 Hr

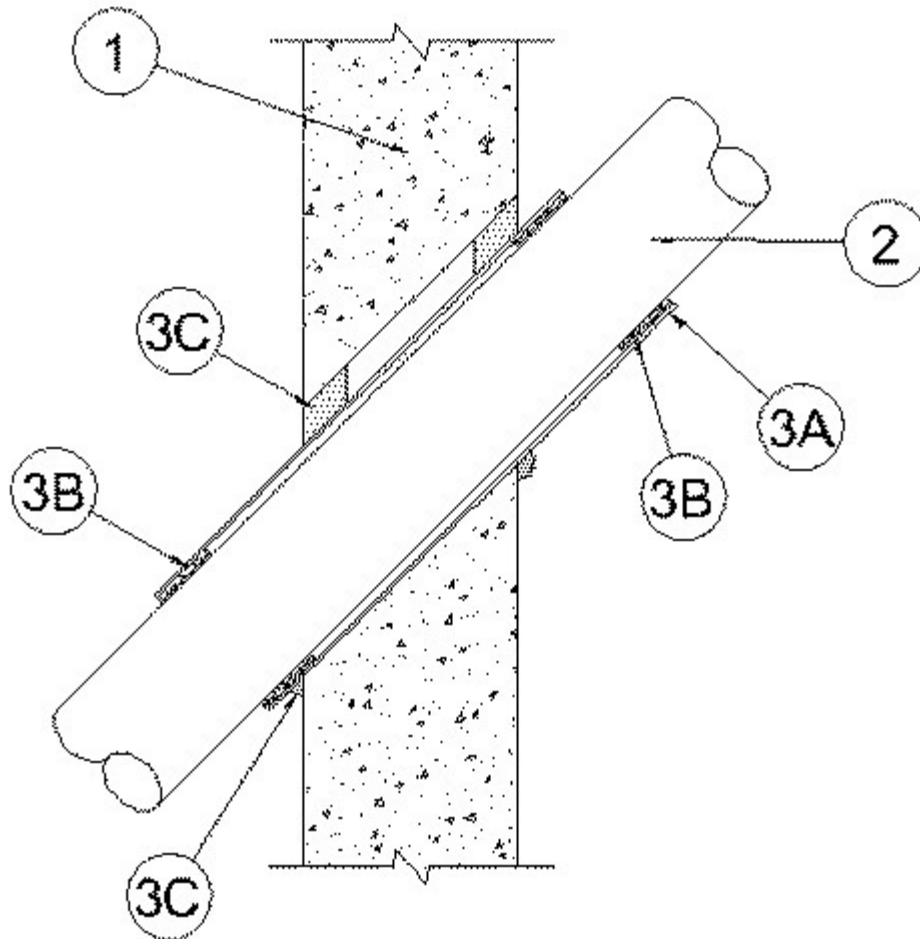

1. **Wall Assembly** — Min 6 in. thick reinforced lightweight or normal weight (100-150 pcf) concrete. Wall may also be constructed of any UL Classified **Concrete Blocks***. Max diam of opening is 6 in.

See **Concrete Blocks** (CAZT) category in the Fire Resistance Directory for names of manufacturers.

2. **Through Penetrants** — One nonmetallic pipe or conduit to be installed concentrically within the firestop system. The annular space between penetrant and sleeve (See item 3A) shall be 1/2 in. The penetrant may be installed at an angle not greater than 45 degrees from perpendicular. Penetrant to be rigidly supported on both sides of wall assembly. The following types and sizes of nonmetallic pipes or conduits may be used:

A. Polyvinyl Chloride (PVC) Pipe — Nom 4 in. diam (or smaller) Schedule 40 cellular core or solid core PVC pipe for use in closed (process or supply) or vented (drain, waste or vent) piping systems.

B. Chlorinated Polyvinyl Chloride (CPVC) Pipe — Nom 4 in. diam (or smaller) SDR 13.5 CPVC pipe for use in closed (process or supply) piping systems.

C. Rigid Non Metallic Conduit+ — Nom 4 in. diam (or smaller) Schedule 40 PVC conduit installed in accordance with Article 347 of the National Electrical Code (NFPA No. 70).

D. Acrylonitrile Butadiene Styrene (ABS) Pipe — Nom 4 in. diam (or smaller) Schedule 40 solid or cellular core ABS pipe for use in closed (process or supply) or vented (drain, waste or vent) piping system.

3. Firestop System — The firestop system shall consist of the following:

A. Metallic Sleeve — Cylindrical sleeve fabricated from min 0.016 in. thick (28 gauge) galv sheet steel and having a min 1 in. lap along the longitudinal seam. Sleeve to extend a min of 1-1/2 in. to a max 2 in. beyond both sides of the wall. The inside diam of the sleeve shall be 1/2 in. larger than outside diam of nonmetallic pipe or conduit such that an annular space will be present between the steel sleeve and the pipe around the entire circumference of the pipe to accommodate the layers of wrap strips (Item 3B). The annular space between the outside of the wrap strip layer(s) and the inside of the sleeve shall be 1/4 in. The annular space between the outside of the sleeve and the periphery of the opening shall be min 0 in. to max 1/2 in.

B. Fill, Void or Cavity Materials* - Wrap Strip — Nom 1/8 in. thick intumescent material supplied in 2 in. wide strips. Two layers of wrap strips are individually wrapped tightly around penetrant with the ends butted and held in place with foil tape. Layers of wrap strip to be recessed into sleeve on both sides of wall such that the outer edges of wrap strips are flush with the outer edges of the sleeve. A min 1/2 in. wide stainless steel hose clamp shall be secured around the outside of the sleeve over the center of the wrap strips on both ends of the sleeve.

EVERKEM DIVERSIFIED PRODUCTS INC — Flame Tech Wrap Strip

C. Fill, Void or Cavity Materials* - Caulk — Min 1-1/4 in. thickness of caulk applied within annulus between metallic sleeve and periphery of the opening, flush with both surfaces of wall assembly. Min 1/2 in. diam bead of caulk shall be applied at the sleeve/concrete interface at the point contact location on both surfaces of wall assembly.

EVERKEM DIVERSIFIED PRODUCTS INC — Firestop 814+

*** Indicates such products shall bear the UL or cUL Certification Mark for jurisdictions employing the UL or cUL Certification (such as Canada), respectively.**