

# System No. F-C-3096

June 13, 2006

F Rating – 1 Hr

T Rating – 1 Hr

F-C 3096

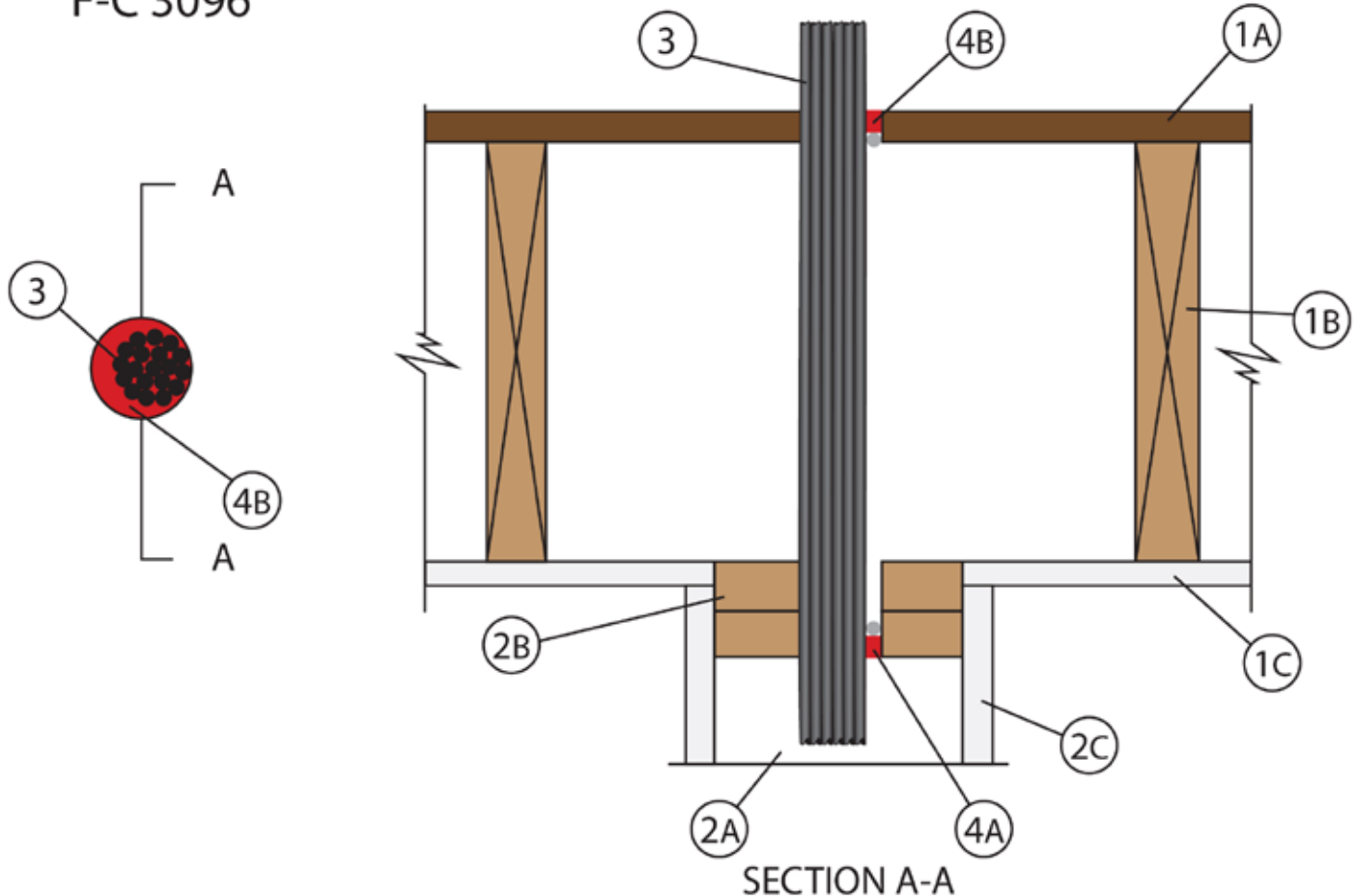

**1. Floor-Ceiling Assembly – The 1 hr fire-rated wood joist floor-ceiling assembly shall be constructed of the materials and in the manner specified in the individual L500 Designs in the UL Fire Resistance Directory, as summarized below:**

**A. Flooring System – Lumber or plywood subfloor with finish floor of lumber, plywood or Floor Topping Mixture\* as specified in the individual Floor-Ceiling Design. Max diam of opening is 3 in.**

**B. Wood Joists – Nom 10 in. deep (or deeper) lumber, steel or combination lumber and steel joists, trusses or Structural Wood Members\* with bridging as required and with ends firestopped.**

**C. Gypsum Board\* – Nom 5/8 in. thick as specified in the individual Floor-Ceiling Design.**

**2. Chase Wall** – The through penetrants (Item 3) shall be routed through a 1 hr fire-rated single, double or staggered wood stud/gypsum board chase wall constructed of the materials and in the manner specified in the individual U300 Series Wall and Partition Designs in the UL Fire Resistance Directory and shall include the following construction features:

**A. Studs** – Nom 2 by 6 in. lumber or double nom 2 by 4 in. lumber studs.

**B. Top Plate** – The double top plate shall consist of two nom 2 by 6 in. lumber plates or two sets of parallel 2 by 4 in. lumber plates, tightly butted. Max diam of opening is 3 in.

**C. Gypsum Board\*** – Thickness, type, number of layers and fasteners shall be as specified in the individual Wall and Partition Design.

**3. Cables** – Aggregate cross-sectional area of cables in opening to be max 33 percent of the cross-sectional area of the opening. Cables to be tightly bundled with bundle installed eccentrically or concentrically within openings. Annular space to be min 0 in. (point contact) to max 3/4 in. Cables to be rigidly supported on both sides of floor assembly. Any combination of the following types and sizes of copper conductor cables may be used:

**A. Max 25 pr No. 24 AWG telephone cables with polyvinyl chloride (PVC) insulation and jacket.**

**B. Max 4 pr No. 24 AWG telephone cables with PVC insulation and jacket.**

**C. Max 2/C with ground No. 12 AWG Type NM nonmetallic sheathed (Romex) cable with PVC insulation and jacket.**

**D. Max RG59/U (or smaller) coaxial cable with fluorinated ethylene insulation and jacketing.**

**4. Firestop System** – The firestop system shall consist of the following:

**A. Packing Material** – Foam backer rod firmly packed into opening as a permanent form. Packing material to be recessed from top surface of subfloor and bottom surface of the lower top plate as required to accommodate the required thickness of fill material.

**B. Fill, Void or Cavity Material\* – Caulk** – Min 1/4 in. thickness of fill material applied within annulus, flush with top surface of subfloor and min 1/2 in. thickness of fill material applied within the annulus, flush with bottom surface of lower top plate. At point contact location, 1/4 in. diam bead of caulk applied at interface of cables and periphery of opening on top surface of floor and bottom surface of lower top plate.

**FLAME TECH INC – Firestop-814+**

**\*Bearing the UL Classification Mark**